

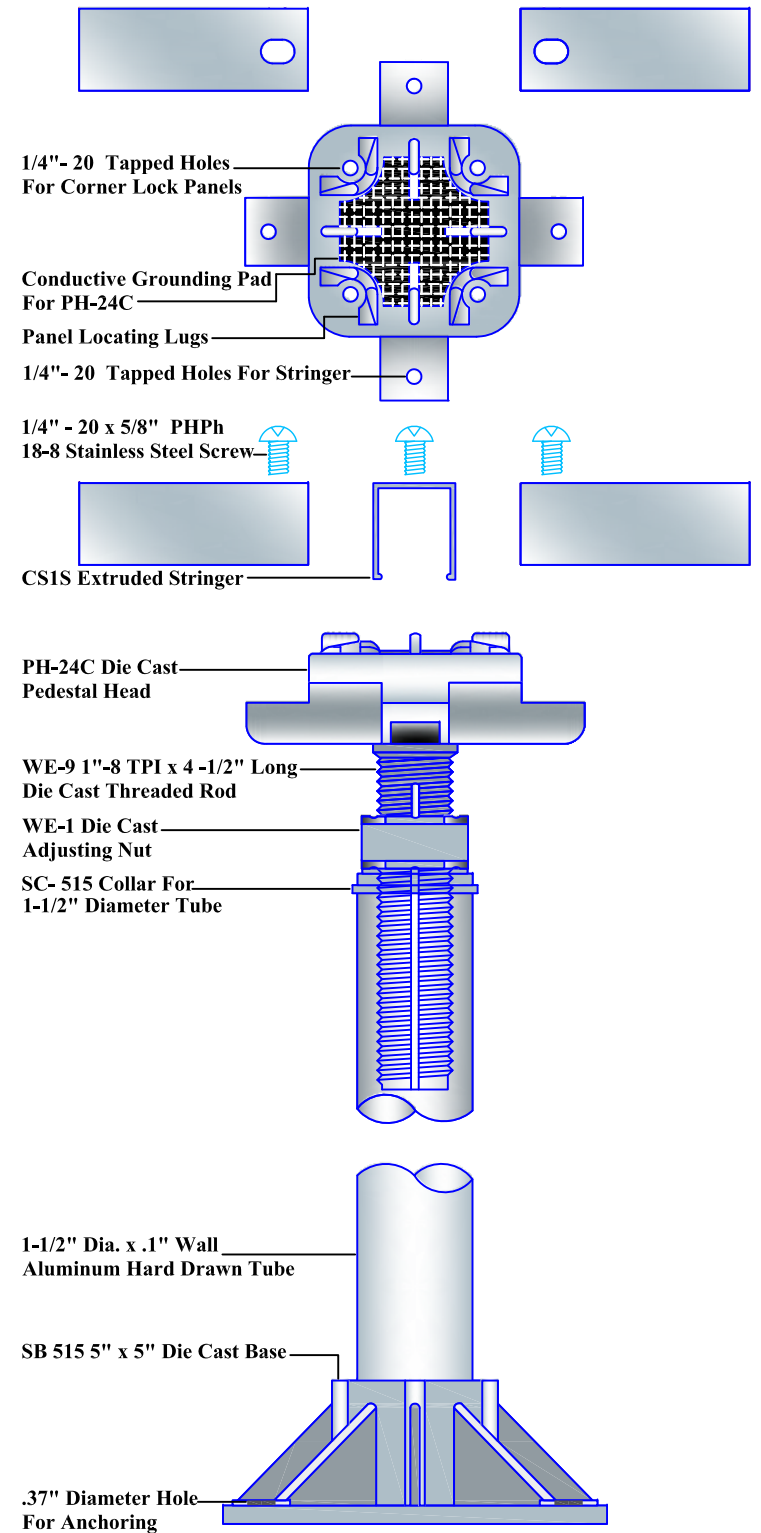

# Data Sheet SB-515

2.00	Model Number	SB-515	
2.10	Units	USCS	SI
2.11	Minimum Finish Floor Height	7 in	17.78 cm.
2.12	Maximum Finish Floor Height Using Standard 4000 Inch-Pound (113Nm) Pedestals with 10 P/F <sup>2</sup> (48kg/m <sup>2</sup> ) Horizontal Load (CAUTION Seismic Load May Reduce Allowable Maximum Height or Increase Pedestal Overturning Moment Requirement, Refer to ASCE7)	48 in	121.92 cm.
2.13	Vertical Load Enhancement	None	
2.14	Stringer Span (Panel x Panel)	1 Panel x 1 Panel	
2.15	Pedestal Spacing	24 in	60.96 cm.
2.15	Uniform Stringer Load at .10" (2.5mm) Deflection	N/A	
2.16	Concentrated Stringer Load at .10" (2.5mm) Deflection	N/A	
2.17	Standard Pedestal Axial Load at Various Finished Floor Heights	7"-24" (18-61cm)	10,000 Lbs 44482 Nm
2.18		25"-36" (63-91cm)	7,000 Lbs 31138 Nm
2.19		37"-48" (94-122 cm)	5,000 Lbs 22241 Nm
2.20	Standard Pedestal Overturning Moment	Adhesive	1,500 in. Lbs 169 Nm
2.21		4 Bolts	4,000 in. Lbs 452 Nm
2.22	Standard Pedestal Base Size	5" x 5"	12.7 cm x 12.7 cm
2.23	Pedestal Tube Diameter	1.50 in	3.81 cm.
2.24	Materials of Construction	Aluminum	
2.25	Ease of Access to Subfloor	High	
2.26	Nonmagnetic (Nonferrous)	Yes	
2.27	Fuel Contribution Factor per ASTM E-84-84	0	
2.28	Flame Spread per ASTM E-84-84	0	
2.29	Smoke Density Factor per ASTM E-84-84	0	
2.30	Static Dissipation	Good	
2.31	Maximum Ohms (DC) Between Uncovered Surface and Pedestal	10	
2.32	Maximum Ohms (DC) Between 2 pedestals 20' Apart	N/A	
2.33	Maximum Ohms at 1 MHz Between 2 pedestals 20' Apart	N/A	
2.34	Suitable For Use As a Signal Reference Grid	No	
2.35	Resistance to Oxidization in High Humidity	Good	
2.36	Resistance to Acids and Polar Solvents	Poor	
2.37	Resistance to Organic (Nonpolar) Solvents	Excellent	
2.38	Suitable Panel Types	All	
2.39	Stringer Dimensions	N/A	
2.40	Weight - Pedestals and Stringers at 24" (61cm) Finish Floor Height	0.6 Lbs/Ft <sup>2</sup>	2.93 Kg/M <sup>2</sup>
2.41	Warranty	1 Year	
2.42	Approximate Delivery	<3000 Ft <sup>2</sup> (300m <sup>2</sup> )	4 Weeks
2.43		>3000 Ft <sup>2</sup> (300m <sup>2</sup> )	8 Weeks



CEI PART #: SB515 Pedestal Assembly		 <b>COMPUTER ENVIRONMENTS, INC.</b> <small>1616 JOHN WEST ROAD DALLAS, TX, USA 75228 214-321-1234 FAX 214-321-2333          Ceifloor.com Maxcessaluminumfloors.com          Manufactured in the U.S.A.</small>
DRAWN BY: M.C.		
PAPER SIZE = 8.5" x 11" LASER		PART OR PROJECT DESCRIPTION
SHEET: 1	SCALE: 1 = 2.5	DATE: 9 Feb 2016
PATH=C:\Users\Ingo\Desktop\Autocad Drawing\Aluminum Pedestals Master.dwg		SB-515 Pedestal Assembly